

ATTENTION: TO INSURE SAFE AND EASY USE OF YOUR WESCO FOLDING TRUCK, READ THESE INSTRUCTIONS BEFORE USING.

This product is distributed by:

**Wesco Industrial Products, LLC**  
1250 Welsh Road  
North Wales, PA 19454  
Tel: 215-699-7031 Fax: 215-699-3836

Contact the factory for parts information and ordering.  
Visit us on the web at [www.wescomfg.com](http://www.wescomfg.com)

### Unpacking

When unpacking the Wesco Product, check carefully for shipping damage and missing parts. If damage has occurred or any parts are missing, file a claim with the delivering carrier within 24 hours and notify the dealer from whom the unit was purchased.

### Parts List

Item	Part No.	Description	Qty.
1		Folding Frame	1
2	272254	Rigid Casters w/ 4" Rubber Wheels	2
3	272253	Swivel Casters with Brake and 4" Rubber Wheels	2
	272291	Swivel Caster with 4" Rubber Wheels and without Brake	2
4		Caster Brackets	4
5		Spacers	4
6		Hex Head Machine Screws	16
7		Lockwashers	16
8		Hex Nuts	16
9		Frame Support	2
10	272220	Hardware Kit (Includes 16 each of items 7, 8 & 9)	1

### Warranty Repairs

If the unit does not work properly, contact your dealer or the factory (215-699-7031) for units less than 90 days old.

### Non-Warranty Service

If units are older than 90 days, repairs can be made easily on site with factory supplied parts.

**NOTE:** Do not send units to the factory for service without first obtaining a "Return Merchandise Authorization" (RMA) number from the customer service department. We will not be responsible for merchandise returned without proper authorization.

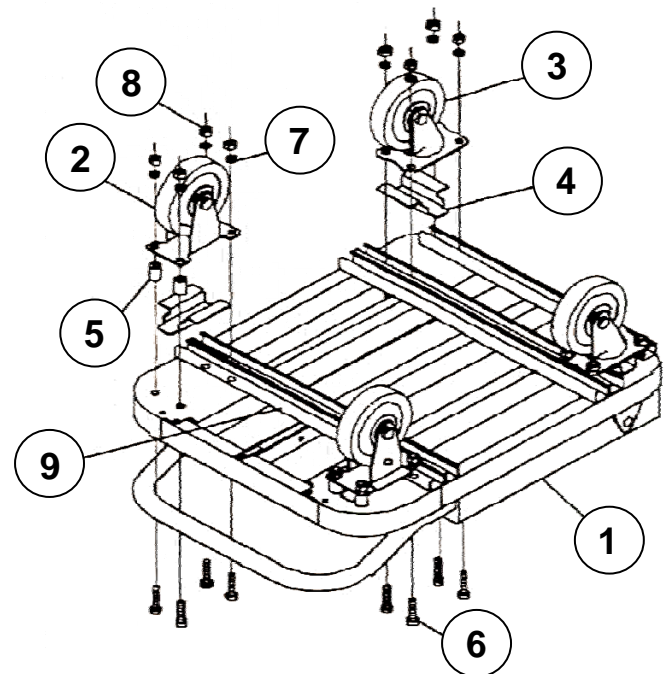

### Assembly

#### A. Rigid Caster Installation

- 1) Unpack platform truck from carton and remove plastic bag. To mount casters to frame, position truck as shown in figure.
- 2) Remove bolts, lockwashers, hex nuts, and spacers from front of frame.
- 3) Insert (4) screws through caster bracket (bracket should be mounted with long flanges facing up, and short flange facing inward).
- 4) Mount a swivel caster onto the screws, and assemble (4) lockwashers and hex nuts to the screws. Tighten hardware. Repeat this procedure for other rigid caster.

#### B. Swivel Caster Installation

- 1) Insert (2) screws through the frame support and caster plate. Assemble (2) lockwashers and hex nuts to the screws. Loosely tighten.
- 2) Slide a caster bracket between the caster plate and the frame as shown. Note: the short flange of the bracket should be facing outward, and the long flanges should be against the caster plate. Place (2) spacers between the frame and the caster plate. Insert (2) screws through the spacers and caster plate. Assemble (2) lockwashers and hex nuts to the screws. Tighten the hardware. Repeat this procedure for other swivel caster.